

- ROBUST STEEL CONSTRUCTION
- 1200 N HOLDING FORCE
- SEALED AGAINST WATER INGRESS IP65 STANDARD
- 24Vdc & 230Vac MODELS AVAILABLE
- SUPPLIED WITH KEEPER PLATE



The Weather Proof Door Holder is designed to hold open fire doors for convenient access through busy door ways and release them for closing when an alarm is triggered. It is designed for wall mounting and is supplied complete with a keeper plate for fixing to the fire door. Both parts are constructed from steel and are zinc plated.

The strong construction makes this magnet ideal for most applications in all types of building. The high level of ingress protection also means that this magnet is particularly suited to use outdoors and in maritime applications.

Electrical connection is via an IP65 connector supplied with the magnet. A wide range of AC and DC voltages are available to order.

TECHNICAL INFORMATION

Electrical supply	24V dc (or 230V ac)
Power rating	7W (or10W)
Holding force	1200 N
Residual force	20N max
Ingress protection	IP65
Ambient temp.	-30° - +80°C
Weight	2.0 Kg
Part number	59-0801-G006 (24Vdc) 59-0801-G008 (230Vac)

KEEPER ASSEMBLY

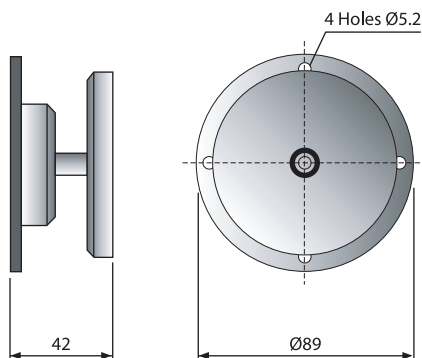

ELECTROMAGNET ASSEMBLY

