

- 24VDC OR 230VAC SUPPLY VOLTAGE
- ZERO RESIDUAL FORCE
- 200N - 500N HOLDING FORCE
- FIRE RESISTANT ABS CASING
- APPROVED TO EN1155 AND CE MARKED
- HIGH QUALITY COST EFFECTIVE PACKAGE
- INCLUDES FITTING INSTRUCTIONS



Electromagnetic Fire Door Holders are designed to hold open Fire Doors in any areas where easy Disability Discrimination Act access is essential, and can be used in conjunction with any suitable fire alarm systems. When an alarm is triggered, power to the door holder is cut, allowing the fire door fitted with it's standard closing mechanism, to shut automatically. Doormouse door holders are fitted with an integral manual release button, allowing the door to be closed without operating the fire alarm.

The Doormouse door holder is surface mounted, and is housed in a white Fire resistant ABS casing. Type tested to meet EN1155, knockouts for surface or back cable entry, and a spring loaded pin to give zero residual holding force when de-energised.

The 230Vac unit includes a filter for EMC emissions and is CE marked. Internal diodes dissipate any "back EMF" on switch-off, reducing wear at the control unit.

The Doormouse is ideal for use in any public access areas including Hospitals, Offices, Hotels and Nursing Homes. Also available as shown below in a decorative finish.

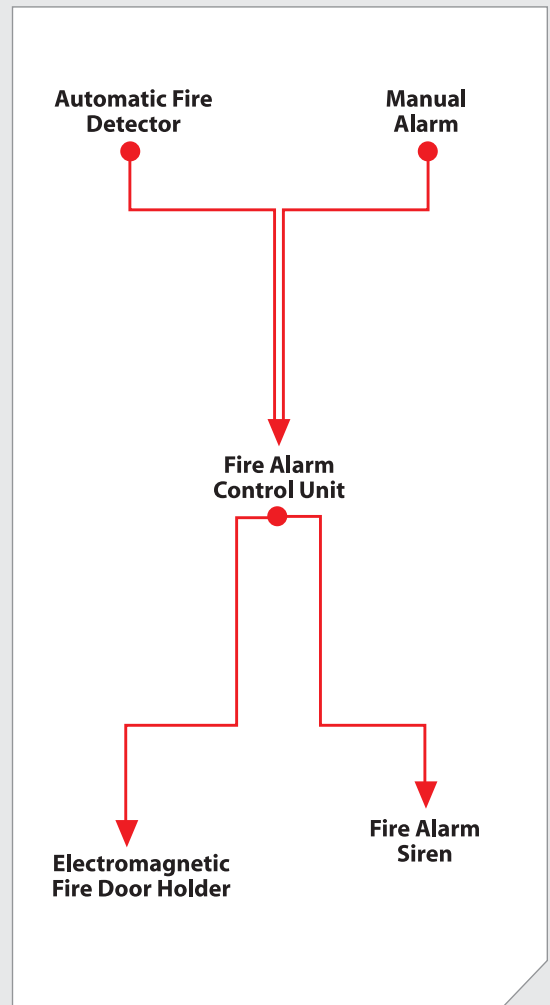

GeoFire reserve the right to change the specifications in this data sheet without prior notification

DOORMOUSE - WALL MOUNTED ELECTROMAGNETIC FIRE DOOR HOLDERS

DOORMOUSE ASSEMBLY

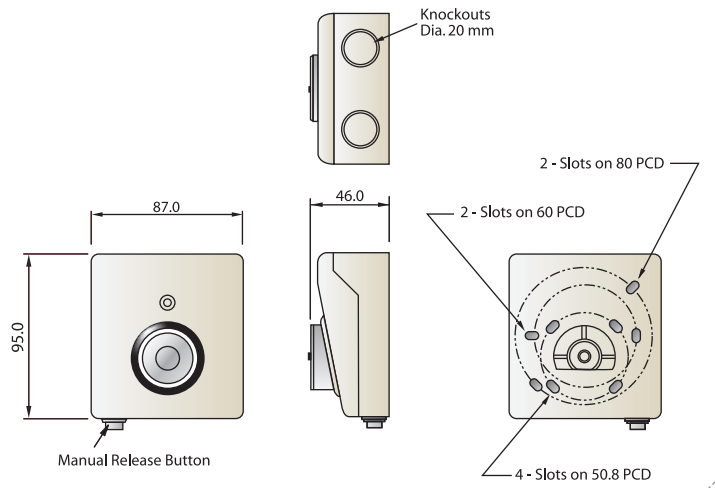

TECHNICAL INFORMATION

Supply Voltage	24Vd.c. or 230 a.c.
Holding Force	200N or 500N
Power Rating	1.15W
Residual Holding force	Zero
Ambient Temperature	0 - 40°C
Protection	IP 51
Casing	White Fire-Res'nt ABS
Weight	360g / 500g

ORDER CODE :

200N : 87-0370 (24 Vdc) . 87-0371 (230 Vac)
 500N : 87-0551 (24 Vdc)

KEEPER PLATES:

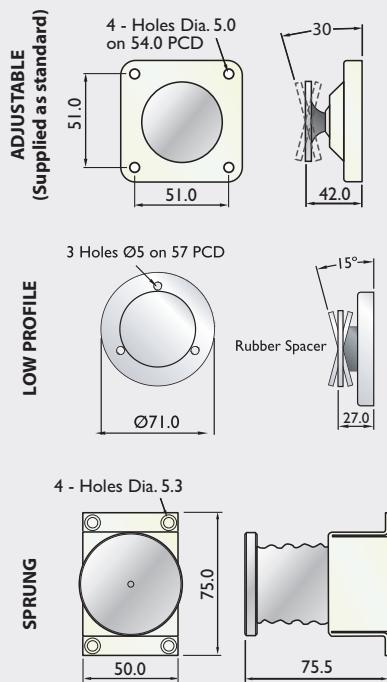

DOORMOUSE FLOOR MOUNTING BRACKET

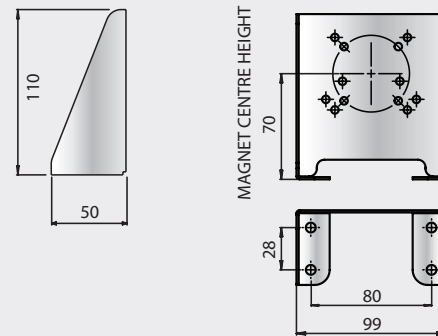

CHAIN KEEPER

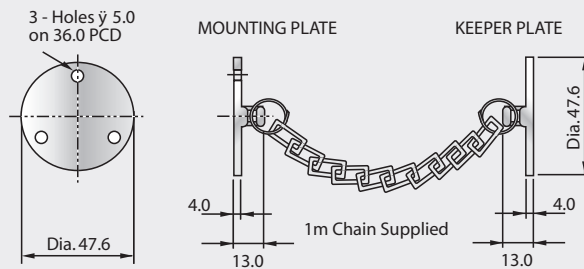

Item Name	Order code
Doormouse F.M. Bracket	34-035G
Chain Keeper	31-0308

Keeper Plates	Holding Force	Adjustment	Order Code
Low Profile	200N	15°	2-31-0307-N237
Adjustable	200N	30°	2-31-0310-U005
Sprung	500N	15°	2-31-0507-Z003
Adjustable	500N	30°	2-31-0507-Z001
Low Profile	500N	15°	2-31-0507-Z011

ACCESSORIES

Each Doormouse is supplied with an adjustable keeper plate as standard. All other accessories should be sold separately. Doormouse Chained Keeper Plates can be used where the standard keeper plate will not reach the door holder due to the door being positioned further towards the centre of the wall.