

- INTEGRAL PART OF ANY FIRE ALARM SYSTEM
- 24VDC OR 230VAC SUPPLY VOLTAGE
- ZERO RESIDUAL FORCE
- 200N HOLDING FORCE
- ROBUST ENCLOSURE
- APPROVED TO EN1155 AND CE MARKED
- IP 51 PROTECTION
- HIGH QUALITY COST EFFECTIVE PACKAGE
- INCLUDES KEEPER PLATE & INSTRUCTIONS

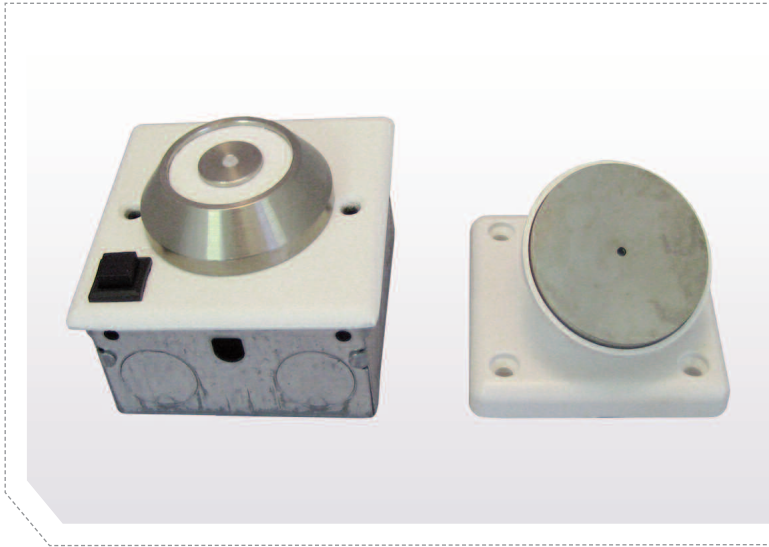

Electromagnetic Fire Door Holders are designed to hold open Fire Doors in any areas where easy Disability Discrimination Act access is essential, and can be used in conjunction with any suitable fire alarm systems or Geofire's Universal floor mounted products. When an alarm is triggered, power to the door holder is cut, allowing the fire door fitted with it's standard closing mechanism, to shut automatically. Conquest door holders are fitted with an integral release button and supplied complete with an adjustable keeper plate and instructions as standard.

The Conquest magnet is built around a robust fascia plate for flush mounting on a standard electrical back box. A spring-loaded pin ensures zero residual holding force. For surface mounting, it is supplied with pressed steel surface mount box with 20 mm knockouts. This product has been successfully type tested to EN1155 and is CE marked under the Construction Products Directive.

The 230Vac unit includes a filter for EMC emissions. Internal diodes dissipate any "back EMF" on switch-off, reducing wear at the control unit.

The Conquest is ideal for use in any public access areas including Hospitals, Cinemas, Airports, Offices, Hotels and Nursing Homes.

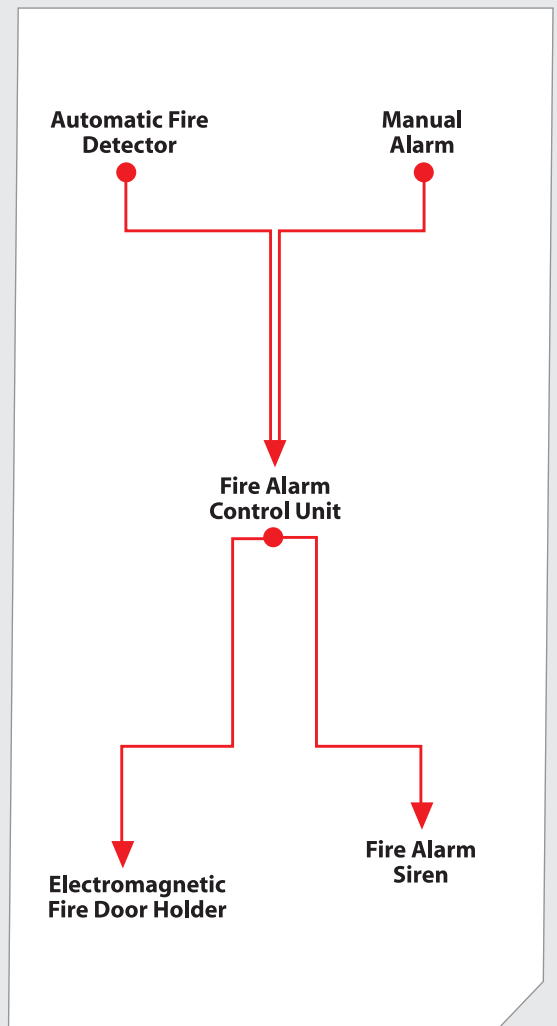

Geofire reserve the right to change the specifications in this data sheet without prior notification

THE TYPE 59 CONQUEST - WALL MOUNTED ELECTROMAGNETIC FIRE DOOR HOLDERS (SURFACE OR FLUSH MOUNT)

TYPE 59 CONQUEST DOOR HOLDER

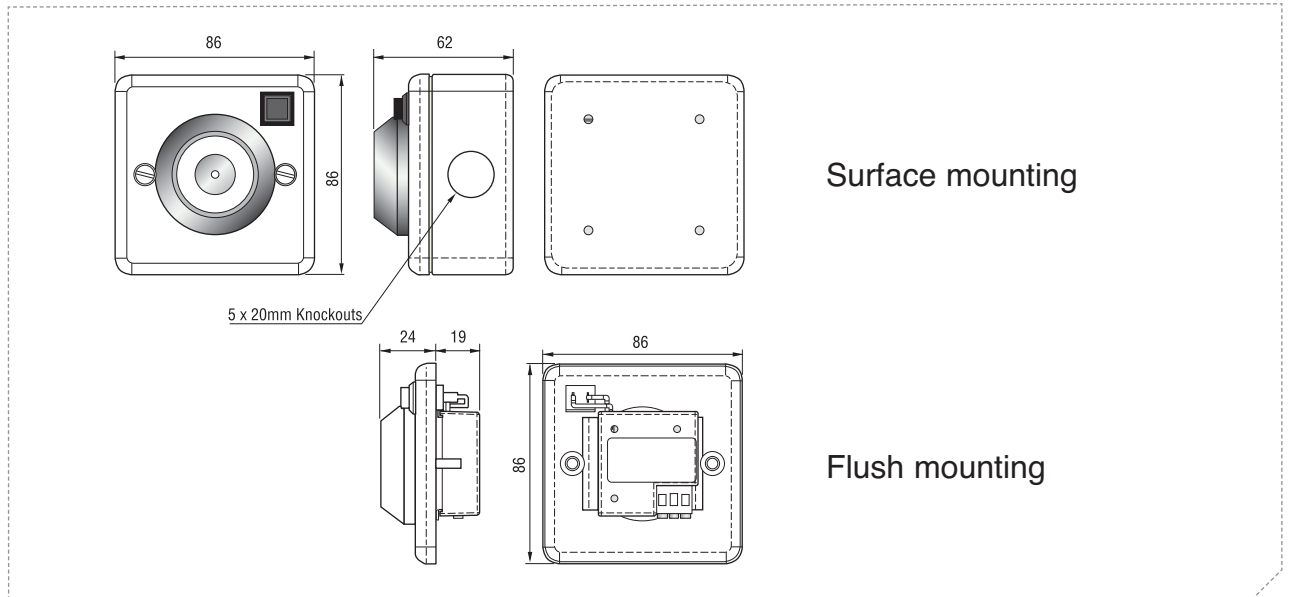

KEEPER PLATE

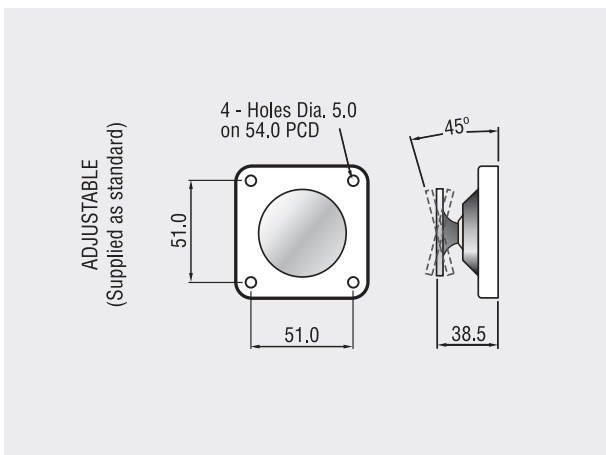

FLOOR MOUNTING BRACKET

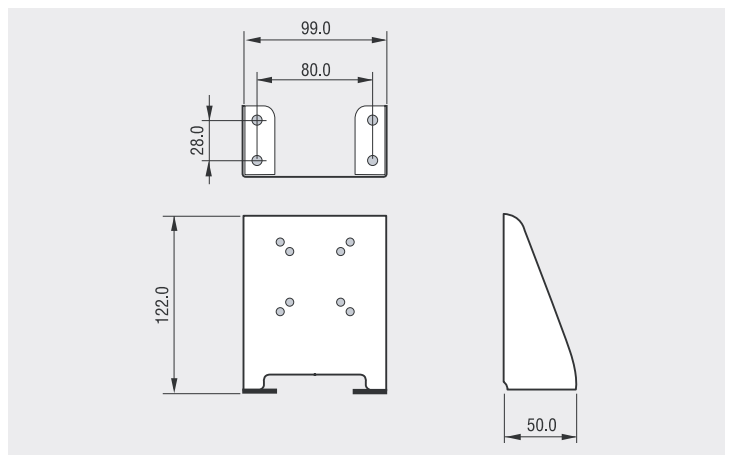

TECHNICAL INFORMATION

Voltage	24Vd.c. or 230Vac
Holding Force	200N (+20%)
Power Rating	1.15W
Residual Holding force	Zero
Ambient Temperature	-10 to 50° C
Ingress Protection	IP 51
Casing	Steel
Weight	420g or 530g
Door Power Rating	3 to 6

ACCESSORIES

Conquest door holders are supplied, as standard, with a flexible Keeper Plate and Installation Instructions. All other accessories are supplied separately.

ORDER CODES:

SURFACE MOUNTED

24 Vdc inc. pressed steel back box & fascia plate: 3-59-0362

230 Vac inc. pressed steel back box & fascia plate : 3-59-0363

FLUSH MOUNTED

24 Vdc inc. pressed steel fascia plate: 3-59-0364

230 Vac inc. pressed steel fascia plate : 3-59-0365

includes
GEOFIRE
 technology